

# QT Series Model QT-5

## Parts Manual

Record of Change 204

This manual contains important safety information and must be carefully read in its entirety and understood prior to installation by all personnel who install, operate and/or maintain this product.

*On-line product registration, parts ordering and warranty information is available at [www.quincycompressor.com](http://www.quincycompressor.com)*

Manual No. 50230-204

December 2011 Edition

# TABLE OF CONTENTS

Overhaul Kit .....1  
 Gasket Set .....1  
 Recommended Spare Parts .....1  
 Serial Number Identification .....2  
 Ordering Replacement Parts .....2  
 Quin-Cip Lubricant .....2  
 Crankcase Lubricant Capacity .....2  
 Crankshaft Groups .....3  
 Crankcase Group .....4  
 Connecting Rod & Piston Groups .....5-6  
 Cylinder & Head Groups .....7-8  
 Control Piping Schematic .....9  
 Pilot Valves .....10  
 Pilot Valve Repair Kit .....10  
 Differential Setting Chart .....10  
 Suction Valve Unloader Assemblies .....11  
 Decals .....11  
 Typical Unit Repair Parts List .....12-14

# INTRODUCTION

This manual provides information for the Model QT-5 reciprocating compressor, per Record of Change 203.

The Model QT-5 is an aircooled, two stage, two cylinder, splash lubricated compressor, with up to 175 PSI continuous pressure capability. It has a 4" low pressure bore and a 2.25" high pressure bore, with a 3" stroke. This compressor can be run at 400-1060 RPM.

Optional head unloaders are available.

# CHANGES

since previous printing dated August 2006:

Record of Change 204

The crankcase and crankshaft groups were redesigned.

Overhaul Kit KQT5FB			
Item #	Qty.	Part Number	Description
	1	111200	piston ring set
	1	111199	piston ring set
	1	114097-002	gasket set
	1	113946X006	valve plate assembly
	1	110377E100	air filter element
	1	110190-013	piston pin
	1	110190-014	piston pin
	1	111333	crankcase breather
	1	113936-001	connecting rod assembly, LP
	1	113936-003	connecting rod assembly, HP
	2	111105-001	piston pin plug, .88 dia
	2	111105-002	piston pin plug, .62 dia

Gasket Set 114097-002			
Item #	Qty.	Part Number	Description
	1	113618-003	gasket, valve plate to head
	1	113617	gasket, cylinder to valve plate
	1	113943	gasket, crankcase to cylinder
	1	113755	gasket, bearing carrier
	1	111106-001	oil seal
	6	114440-L23	hex. screw, 3/8-16 unc x 3.50
	6	110428N038	flatwasher, 3/8
	1	50278-101	head bolt torque instructions

Recommended Spare Parts			
Item #	Qty.	Part Number	Description
	1	110377E100	air filter element, (fits 110377S100 and 110377S101 air filters; optional)
	1	114097-002	gasket set
	1	114096-002	replacement valve assembly

## SERIAL NUMBER IDENTIFICATION

The unit serial number identification tag is located on the air tank top plate. The basic compressor serial number decal is located on the side of the crankcase opposite the oil fill side. *Fill in the numbers from your compressor unit and basic compressor in the corresponding spaces provided here, and reference this page when ordering replacement parts.*

Unit Serial Number
_____
Basic Serial Number
_____

All replacement parts are to be ordered through an authorized Quincy distributor. Insist on genuine Quincy parts only! Failure to do so may void warranty.

## ORDERING REPLACEMENT PARTS

Prompt service can be rendered on repair parts orders if the following information is given:

- Item 1)** the model number, record of change number, & serial number.
- Item 2)** the exact part number needed. (Do not order by item numbers.)
- Item 3)** the exact quantity needed.
- Item 4)** the preferred type of transportation.

## CRANKCASE LUBRICANT CAPACITY

Model	Capacity
QT-5	1 <sup>5</sup> / <sub>8</sub> qts. (1.5 lit.)

## QUIN-CIP LUBRICANT

Refer to the chart below to order Quin-Cip-D or Quin-Cip compressor lubricant from your local authorized Quincy distributor.

<b>Quin-Cip-D Lubricant (synthetic)</b>	
<b>SAE 30 (ISO 100)</b>	
Quart	115468Q
Case (12 Qts.)	115438C
<b>Quin-Cip Lubricant</b>	
<b>SAE 10W (ISO 32)</b>	
Quart	112541Q032
Case (12 Qts.)	112541C032
<b>SAE 20 (ISO 68)</b>	
Quart	112542Q068
Case (12 Qts.)	112542C068
<b>SAE 30 (ISO 100)</b>	
Quart	112543Q100
Case (12 Qts.)	112543C100

**CAUTION !**

Refer to the QT & QTS Series instruction manual for vital lubrication information.

**CAUTION !**

Follow all safety precautions outlined in the QT & QTS Series instruction manual.

**WARNING !**

Do not operate this compressor without a totally enclosed belt guard or any other required safety equipment.

**DANGER !**

Air used for breathing or food processing must meet OSHA 1910.134 or FDA 21 CFR 178.3570 regulations. Failure to do so may cause severe injury or death.

# CRANKSHAFT GROUP 113684-004

ITEM	PART NUMBER	QTY	DESCRIPTION
1	113602X002	1	CRANKSHAFT ASSEMBLY (INCLUDES SHAFT AND BEARINGS)
2	113602-002	1	CRANKSHAFT (N.S.S. - ORDER CRANKSHAFT ASSEMBLY)
3	111107	1	BALL BEARING
4	111780	1	BALL BEARING
5	113944-001	1	SHEAVE, 14.15 O.D., 2 GROOVE, B SECT. CCW
6	110428N075	2	FLAT WASHER, 3/4
7	114041	1	HEX NUT, 3/4-16 UNF, L.H. THREAD

N.S.S. = NOT SOLD SEPARATE

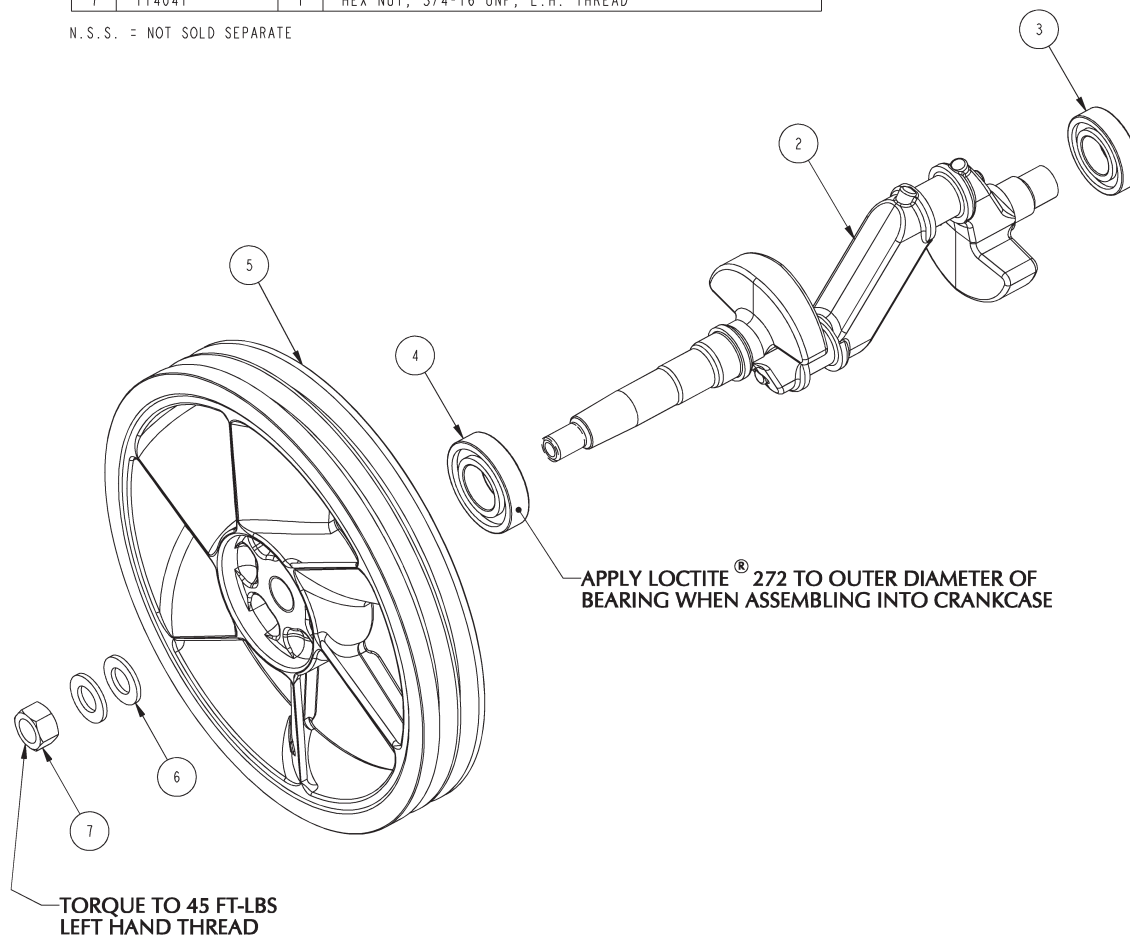

# CRANKCASE GROUP 113683-002

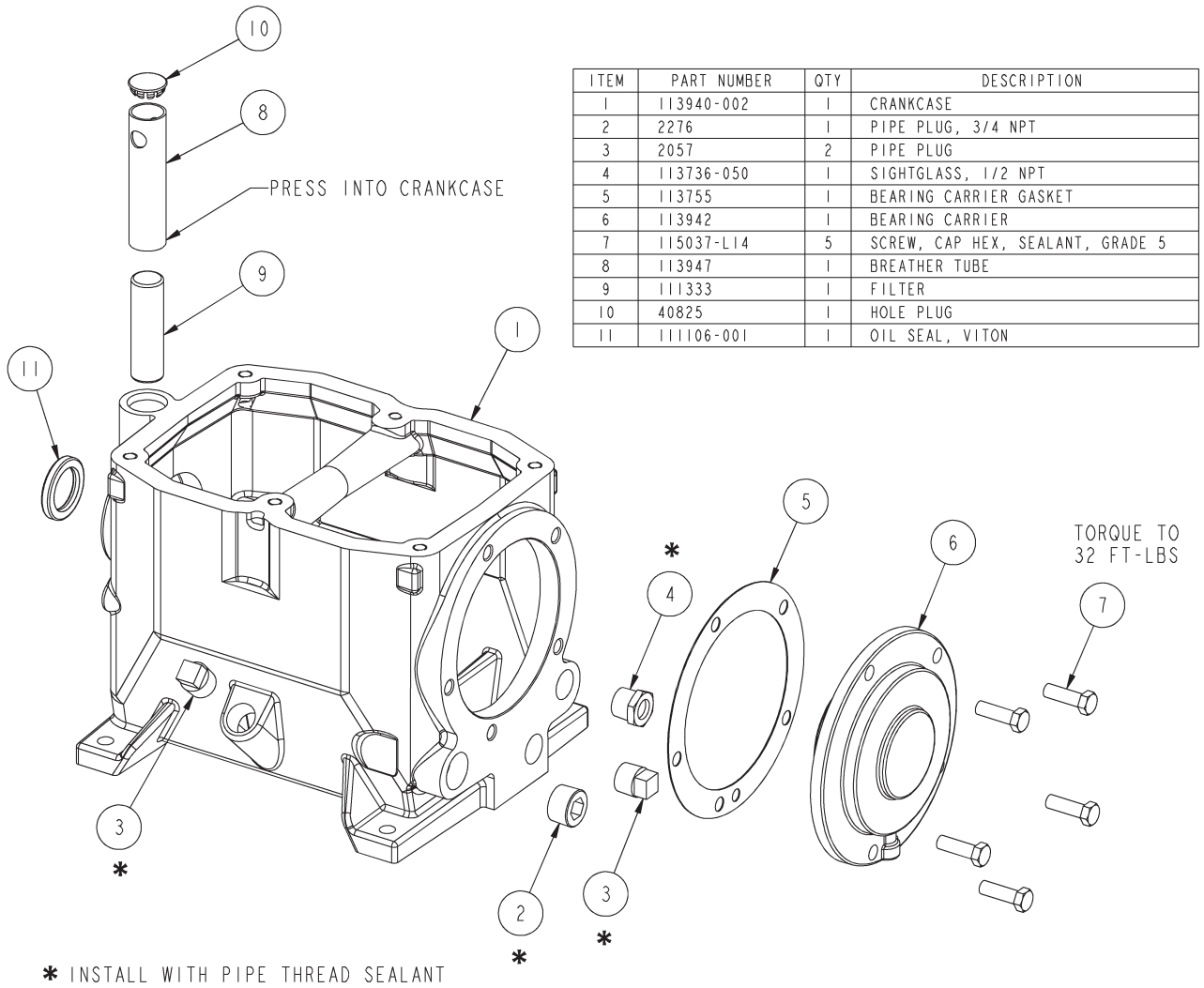

# CONNECTING ROD & PISTON GROUP 113686

(low pressure)

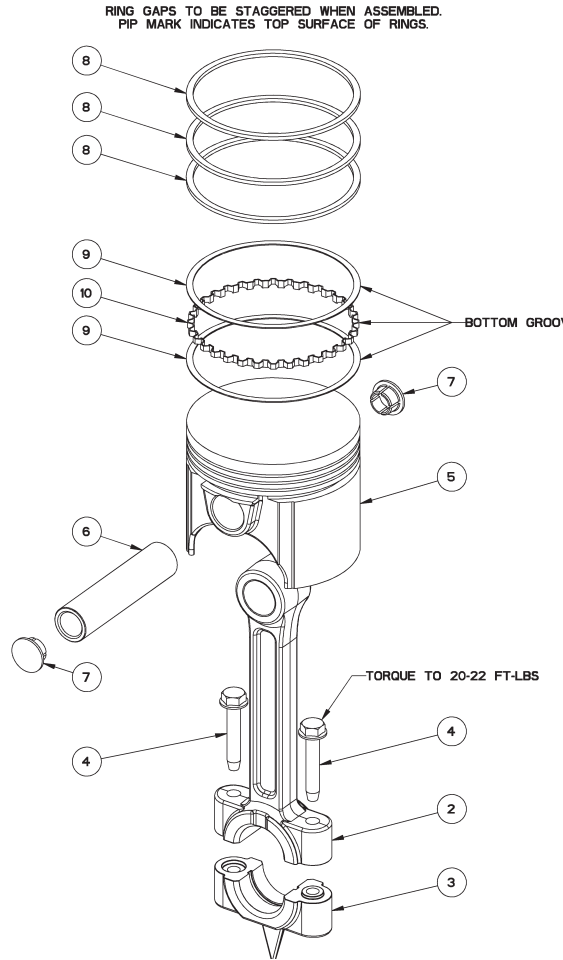

113686 LOW PRESSURE PISTON AND ROD GROUP			
ITEM	PART NUMBER	QTY	DESCRIPTION
1	113936-001	1	CONNECTING ROD ASSEMBLY (INCLUDES ROD, CAP, SCREWS)
2	113936R	1	CONNECTING ROD, N.S.S., ORDER ROD ASSEMBLY
3	113937R	1	CONNECTING ROD CAP, N.S.S., ORDER ROD ASSEMBLY
4	110511-K16	2	TAPTITE SCREW, 5/16-18 UNC X 1.75
5	113609	1	PISTON, LOW PRESSURE
6	110190-013	1	PISTON PIN
7	111105-001	2	PISTON PIN PLUG
8	111330	3	PISTON RING
9	6591	2	OIL RING RAIL
10	6590	1	OIL RING EXPANDER

MAINTENANCE PARTS		
PART NUMBER	QTY	DESCRIPTION
111199	1	PISTON RING SET INCLUDES ALL RINGS NECESSARY FOR INSTALLING STANDARD RINGS
113609X	1	PISTON ASSEMBLY, LP INCLUDES PISTON, RING SET, PISTON PIN, AND PISTON PIN PLUGS
110190-050	1	REPLACEMENT PISTON PIN ASSEMBLY, LP INCLUDES PISTON PIN AND PLUGS

N.S.S. = NOT SOLD SEPARATE

# CONNECTING ROD & PISTON GROUP 113687

(high pressure)

RING GAPS TO BE STAGGERED WHEN ASSEMBLED.  
PIP MARK INDICATES TOP SURFACE OF RINGS.

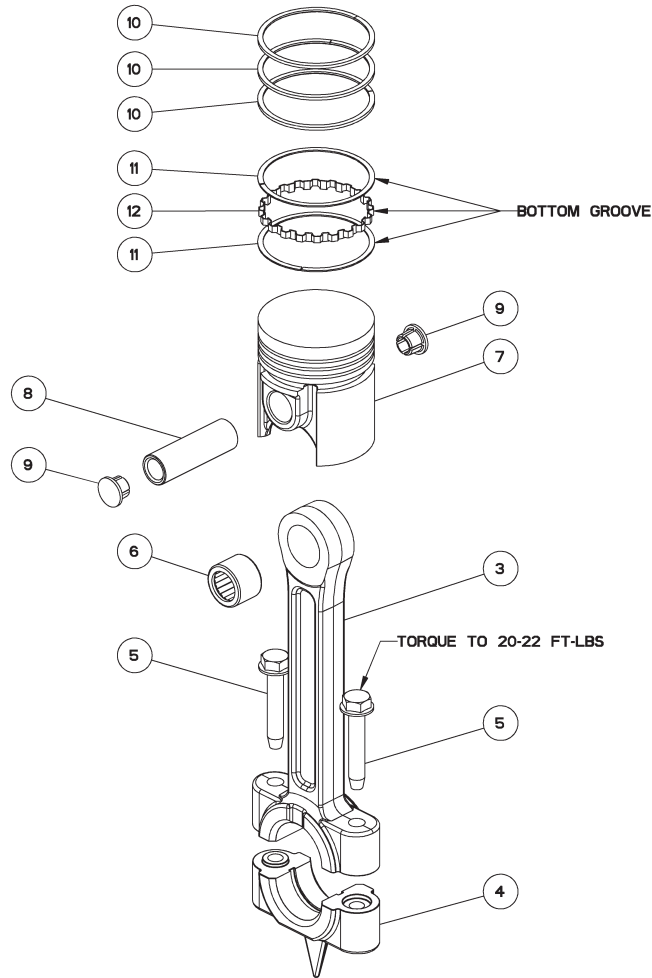

113687 HIGH PRESSURE PISTON AND ROD GROUP			
ITEM	PART NUMBER	QTY	DESCRIPTION
1	113936X006	1	CONNECTING ROD ASSEMBLY, WITH BEARING
2	113936-006	1	CONNECTING ROD ASSEMBLY (INCLUDES ROD,CAP,SCREWS)
3	113936R	1	CONNECTING ROD, N.S.S., ORDER ROD ASSEMBLY
4	113937R	1	CONNECTING ROD CAP, N.S.S., ORDER ROD ASSEMBLY
5	110511-K16	2	TAPTITE SCREW, 5/16-18 UNC X 1.75
6	111112	1	NEEDLE BEARING
7	113610	1	PISTON, HIGH PRESSURE
8	110190-014	1	PISTON PIN
9	111105-002	2	PISTON PIN PLUG
10	111114	3	PISTON RING
11	111124	2	OIL RING RAIL
12	111123	1	OIL RING EXPANDER

MAINTENANCE PARTS			
PART NUMBER	QTY	DESCRIPTION	
111200	1	PISTON RING SET	
113610X	1	PISTON ASSEMBLY, HP INCLUDES PISTON, RING SET, PISTON PIN, AND PISTON PIN PLUGS	
110190-051	1	REPLACEMENT PISTON PIN ASSEMBLY, HP INCLUDES PISTON PIN AND PLUGS	

N.S.S. = NOT SOLD SEPARATE

# CYLINDER & HEAD GROUP 113685

(less head unloaders)

ITEM	PART NUMBER	QTY	DESCRIPTION
1	113941	1	CYLINDER
2	113617	1	GASKET, VALVE PLATE TO CYLINDER
3	113946X	1	VALVE PLATE ASSEMBLY
4	113946R	1	VALVE PLATE (N.S.S., ORDER VALVE PLATE ASSEMBLY)
5	112360	1	REED VALVE (N.S.S., ORDER V.P. ASSEMBLY)
6	112378-1	1	BUMPER (N.S.S., ORDER V.P. ASSEMBLY)
7	112359-1	1	REED VALVE (N.S.S., ORDER V.P. ASSEMBLY)
8	112381-1	1	BUMPER (N.S.S., ORDER V.P. ASSEMBLY)
9	112359-2	2	REED VALVE (N.S.S., ORDER V.P. ASSEMBLY)
10	112379	1	BUMPER (N.S.S., ORDER V.P. ASSEMBLY)
11	112381-2	1	BUMPER (N.S.S., ORDER V.P. ASSEMBLY)
12	112728-J12	4	FLATHEAD SCR., 1/4"-20UNC X 1.00., GR 8
13	112373-J02	4	HEX NUT, 1/4"-20 UNC
14	113618-003	1	GASKET, VALVE PLATE TO HEAD
15	113613M001	1	CYLINDER HEAD, PLAIN
16	114559038	6	FLAT WASHER, 3/8
17	114440-L22	6	HEX. SCREW, 3/8-16 UNC X 3.25, GRADE 9
18	113943	1	GASKET, CYLINDER TO CRANKCASE
19	113606	1	INTERCOOLER (N.S.S., ORDER REPLACEMENT KIT)
20	2961-100	1	PRESSURE RELIEF VALVE
21	110919-024	2	TUBE FITTING, 90° ELBOW, 3/4"x3/4"AMP
22	112225-2	1	INTERCOOLER CLAMP
23	123478-L10	1	HEX. SCREW, 3/8-16 UNC X .75, GRADE 5
24	115037-L14	6	SCREW, CAP HEX., SEALANT, GRADE 5

PART NUMBER	QTY	DESCRIPTION
114096-002	1	VALVE ASSEMBLY REPLACEMENT KIT INCLUDES ITEMS 2, 3, 14, 16, 17 AND INSTRUCTIONS
113606K	1	INTERCOOLER REPLACEMENT KIT INCLUDES INTERCOOLER AND NUT/SLEEVE FITTINGS
K0T5EB	1	HEAD REPLACEMENT KIT INCLUDES REPLACEMENT VALVE ASSEMBLY AND AIR FILTER ELEMENT
110377S100	1	AIR FILTER / SILENCER
110377S101	1	AIR FILTER / SILENCER (FOR ENGINE DRIVEN MODELS)
110377E100	1	ELEMENT, AIR FILTER

N.S.S. = NOT SOLD SEPARATE  
\* INSTALL WITH TEFLON® TAPE

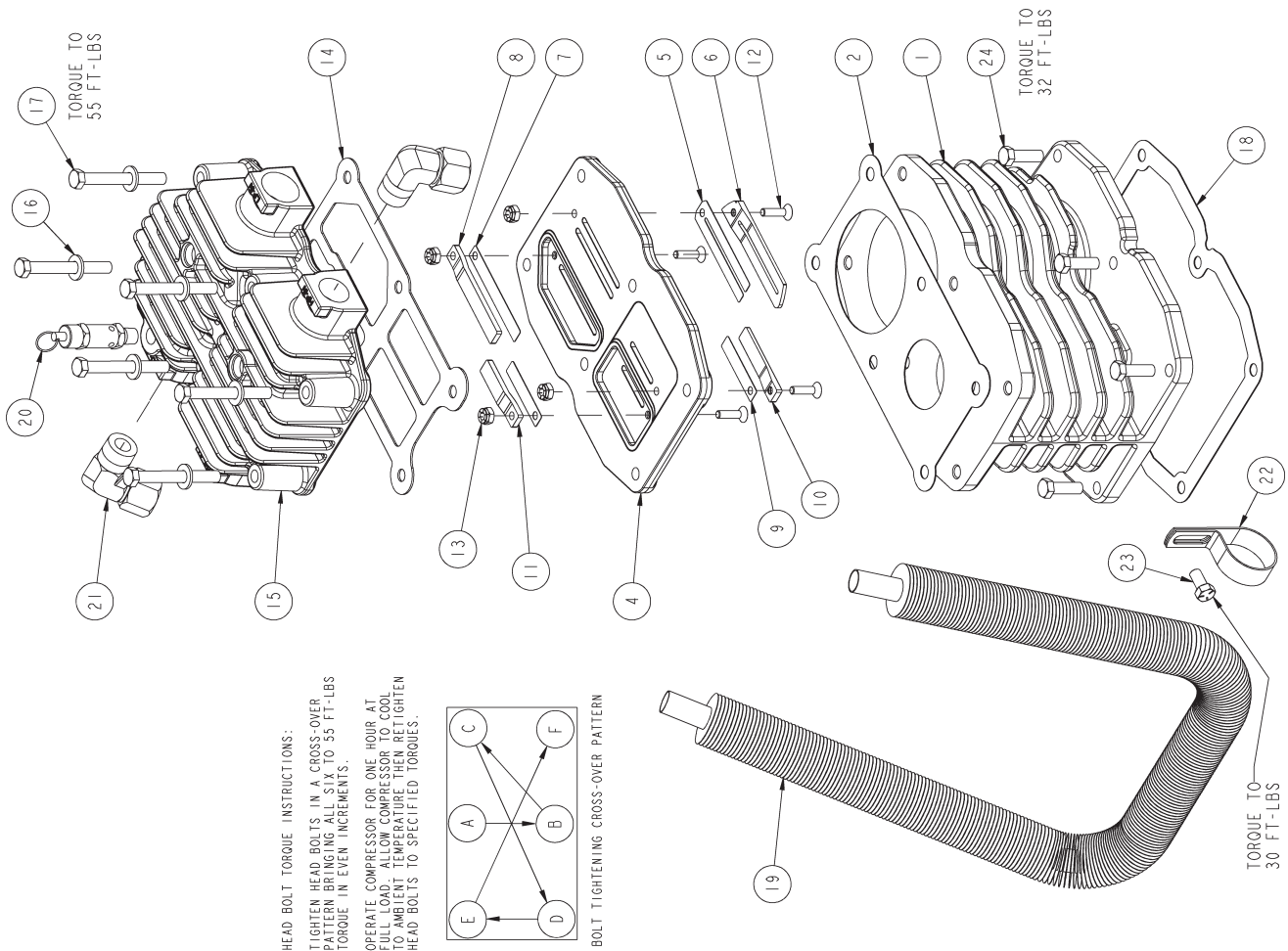

**HEAD BOLT TORQUE INSTRUCTIONS:**  
TIGHTEN HEAD BOLTS IN A CROSS-OVER PATTERN BRINGING ALL SIX TO 55 FT-LBS TORQUE IN EVEN INCREMENTS.

**OPERATE COMPRESSOR FOR ONE HOUR AT FULL LOAD. ALLOW COMPRESSOR TO COOL TO AMBIENT TEMPERATURE BEFORE TIGHTEN HEAD BOLTS TO SPECIFIED TORQUES.**

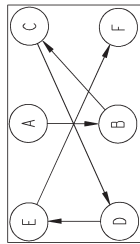

BOLT TIGHTENING CROSS-OVER PATTERN



# CYLINDER & HEAD GROUP 113685-001

(with head unloaders)

ITEM	PART NUMBER	QTY	DESCRIPTION
1	113941	1	CYLINDER
2	113617	1	GASKET, VALVE PLATE TO CYLINDER
3	113946X	1	VALVE PLATE ASSEMBLY
4	113946R	1	VALVE PLATE (N.S.S., ORDER VALVE PLATE ASSEMBLY)
5	112380	1	REED VALVE (N.S.S., ORDER V.P. ASSEMBLY)
6	112378-1	1	BUMPER (N.S.S., ORDER V.P. ASSEMBLY)
7	112359-1	1	REED VALVE (N.S.S., ORDER V.P. ASSEMBLY)
8	112381-1	1	BUMPER (N.S.S., ORDER V.P. ASSEMBLY)
9	112359-2	2	REED VALVE (N.S.S., ORDER V.P. ASSEMBLY)
10	112379	1	BUMPER (N.S.S., ORDER V.P. ASSEMBLY)
11	112728-J12	1	BUMPER (N.S.S., ORDER V.P. ASSEMBLY)
12	112728-J12	4	FLATHEAD SCR. 1/4-20UNC X 1.00, GR 8
13	112373-J02	4	HEX NUT, 1/4-20 UNC
14	113618-003	1	GASKET, VALVE PLATE TO HEAD
15	113613-001	1	CYLINDER HEAD, UNLOADER
16	11455038	6	FLAT WASHER, 3/8
17	114440-L22	6	HEX. SCREW, 3/8-16 UNC X 3.25, GRADE 9
18	113943	1	GASKET, CYLINDER TO CRANKCASE
19	113606	1	INTERCOOLER (N.S.S., ORDER REPLACEMENT KIT)
* 20	2961-100	1	PRESSURE RELIEF VALVE
* 21	110919-024	2	TUBE FITTING, 90° ELBOW, 3/4TX3/4MP
22	112225-2	1	INTERCOOLER CLAMP
23	123478-L10	1	HEX SCREW, 3/8-16 UNC X .75, GRADE 5
24	115037-L14	6	SCREW, CAP HEX, SEALANT, GRADE 5
* 25	111591X1	1	UNLOADER, INTAKE, LP
* 26	111591X2	1	UNLOADER, INTAKE, HP
27	112708-908	2	*O-RING, SILICONE
* 28	2708	1	TUBE FITTING, 90° ELBOW, 1/4TX1/4MP
* 29	124351-004	1	MALE BRANCH TEE 1/4" X 1/4"

PART NUMBER	QTY	DESCRIPTION
114096-002	1	VALVE ASSEMBLY REPLACEMENT KIT INCLUDES ITEMS 2, 3, 14, 16, 17 AND INSTRUCTIONS
113606K	1	INTERCOOLER REPLACEMENT KIT INCLUDES INTERCOOLER AND NUT/SLEEVE FITTINGS
K075EB	1	HEAD REPLACEMENT KIT INCLUDES REPLACEMENT VALVE ASSEMBLY AND AIR FILTER ELEMENT
110377S100	1	AIR FILTER / SILENCER
110377S101	1	AIR FILTER / SILENCER (FOR ENGINE DRIVEN MODELS)
110377E100	1	ELEMENT, AIR FILTER

N.S.S. = NOT SOLD SEPARATE  
\* INSTALL WITH TEFLON® TAPE

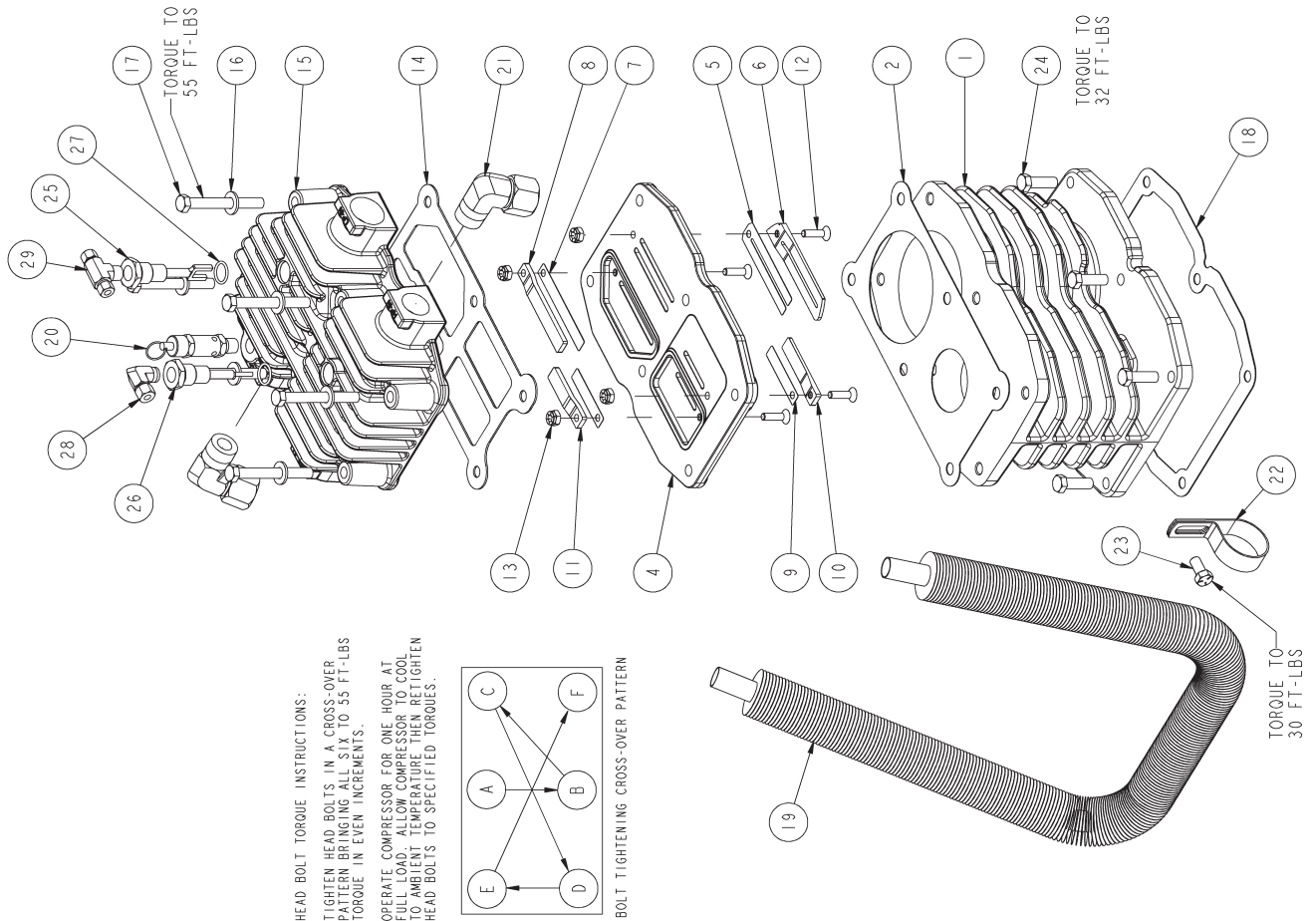

# CONTROL PIPING SCHEMATIC

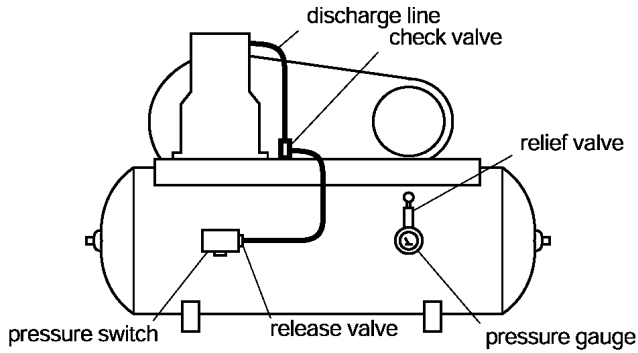

**Control Piping  
For Automatic Start/Stop**

*(with loadless starting)*

**Control Piping  
For Continuous Run**

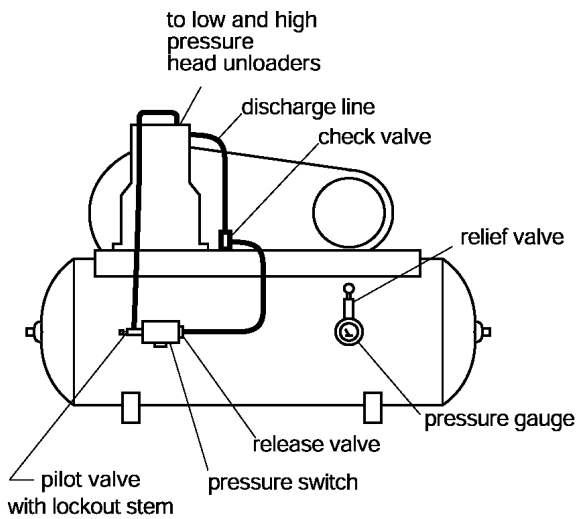
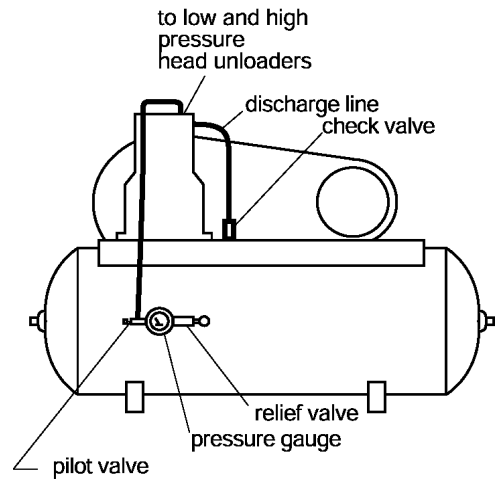

**Control Piping  
For Dual Control**

*For Start / Stop operation  
the pilot valve is open  
(stem screwed out)*

*For Continuous Run operation  
the pilot valve is closed  
(stem screwed in)*

PIX 1186.eps

# PILOT VALVES

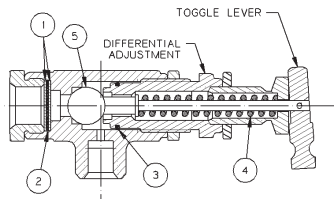

## 110832 Series Pilot Valve (continuous run operation)

Add dash # listed below to 110832 (per pressure setting) to obtain correct pilot valve.

Dash #	Load PSI	Unload PSI
-100	90	100
-997	*	30-70 adjustable
-998	*	71-150 adjustable
-999	*	151-175 adjustable

\* Customer to set, see differential setting chart. Additional factory preset valves are available upon request.

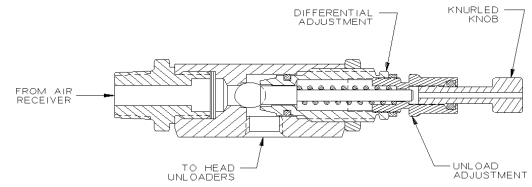

## 110998 Series Pilot Valve (dual control operation)

Add dash # listed below to 110998 (per pressure setting) to obtain correct pilot valve.

Dash #	Load PSI	Unload PSI
-115	100	115
-140	125	140
-165	150	165

## Pilot Valve Repair Kit 110832-051

Can be used to repair 110832 series pilot valves only. Customer must specify which spring when ordering kit.

Item #	Qty.	Part Number	Description
1	2		screen
2	1		filter
3	1		"o"ring
4	1	see chart below	pilot valve spring
5	1		ball

## Differential Setting Chart

Applies to 110998 series pilot valves only.

Unload (PSI)	Min. Dif. (PSI)	Max. Dif. (PSI)
40	2	5
60	3	10
100	4	20
150	5	30
175	5	45

## Differential Setting Chart

Spring Part # (item 4)	Unload (PSI)	Min. Dif. (PSI)	Max. Dif. (PSI)
110832-052 (red)	30	2	4
"	40	5	8
"	50	5	8
"	60	5	8
"	70	5	10
110832-053 (yellow)	80	5	10
"	90	5	12
"	100	5	13
"	110	5	15
"	120	5	15
"	130	5	18
"	140	5	18
"	150	5	20
110832-054 (green)	160	5	15
"	170	5	20
"	175	5	23

## WARNING !

Not all pilots are for use with all compressor systems. Make sure that the pilot you order is set within the safe operating limits of your compressor. Failure to heed this warning could result in an explosion.

# SUCTION VALVE UNLOADER ASSEMBLIES

## Description

The Quincy suction valve unloader assembly consists of unloading assemblies on the suction valves, having a plunger to contact the suction valve reed and an unloader pilot valve (110832 or 110998 series) to automatically regulate the passing of air tank pressure to the unloading arrangement.

## Continuous Run Operation

Suction valve unloader assemblies are recommended for use on Quincy compressors where the compressor is to run continuously and a constant pressure is to be maintained. The purpose is to automatically unseat the suction valve of the compressor when the air supply is greater than the demand.

Unloading occurs when air tank pressure is sufficient to overcome pilot valve spring pressure. The check ball is then unseated, allowing air tank pressure to pass to the unloader assemblies. The compressor will run unloaded until the air tank pressure drops to a predetermined level. At this time, the action of the ball is reversed, shutting off air tank pressure to the unloader assemblies and venting the unloader to atmosphere. This allows the compressor to load. The drive, either electric motor or engine, runs continuously and must be started and stopped manually. 110832 series pilot valves feature a toggle lever which can be flipped to provide manual unloading.

## Dual Control Operation

Dual control operation is designed to provide a choice between "start/stop" or "continuous run" operation. The 110998 series pilot valve can be set for "start/stop" operation by turning the knurled knob at the end of the pilot valve (refer to illustration for 110998 series pilot valve) clockwise until it stops. Under these circumstances, a pressure switch is required to stop the motor. Failure to use a pressure switch, with the pilot valve locked out, will result in unsafe conditions.

### WARNING !

A pressure switch must be incorporated whenever 110998 series pilot valve is employed as part of the control system.

The compressor will operate in the continuous run mode if the knurled knob is turned counterclockwise until it stops.

## Installation

The pilot valve is mounted directly into the air tank. Compressors in the field, not equipped with these controls, can be converted. Consult your local Quincy distributor for assistance with conversion procedures.

## Service

If a change in pilot valve operation is detected, remove the pilot valve from the air tank and check the screen in the inlet of the pilot valve for obstructions. Clean the screen if necessary.

## Adjustment

The unloading pressure is adjustable and is regulated by turning the unload adjustment hex nut (refer to pilot valve illustrations). Turn the hex nut clockwise to increase and counterclockwise to decrease the unloading pressure.

The differential (difference between unloading and loading pressure) is set by turning the differential adjustment hex nut (refer to pilot valve illustrations). Increase the differential pressure by turning the hex nut clockwise - decrease by turning counterclockwise. Make all adjustments in small increments. Tighten the locknuts after adjustment.

## DECALS

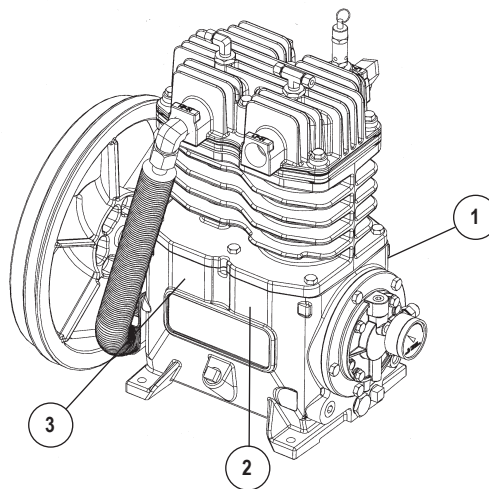

Decals			
Item #	Qty.	Part Number	Description
1	1	110831	serial number & nameplate
2	1	127889-A	decal, CAUTION!, MANUAL
3	1	127889-B	decal, DANGER!, "Air from this...."

# TYPICAL UNIT REPAIR PARTS LIST

The parts listed here are for standard QT-5 (up to 175 PSI) units and may or may not be applicable to custom built units. Check with your local authorized Quincy distributor for parts that can be used for custom built units. Make sure the components you order are rated within the safe operating limits of your system. If you are doubtful about which components to order, contact your local Quincy distributor.

(QT-5 simplex - horizontal tank - electric motor)

Qty	Part Number	Part Number	Part Number	Description
	<b>60 gal.</b>	<b>80 gal.</b>		
1	113891-200	113268-200		tank (200 PSI maximum operating pressure)
1	2713	2713		tank drain valve
1	111136-075	111136-075		service valve
1	110514-200	110514-300		pressure gauge
1	110512-005	110512-005		pressure switch
1	110513-200	110513-200		pressure relief valve (in tank; 200 PSI)
1	111089-215	111089-215		pressure relief valve (in discharge line; 215 PSI)
1	111491	111491		check valve
4 ft.	110515-075	110515-075		discharge tube
2	110948-075	110948-075		tube fitting (nut with sleeve)
1	2021030889	2021030889		belt guard assembly
	<b>3 h.p.</b>	<b>5 h.p.</b>		
1	110357B057	110258B060		drive belt
1	3844-118	3852-118		motor pulley
	<b>115/230v, 1Ø</b>	<b>200v, 3Ø</b>	<b>230/460v, 3Ø</b>	
1	4003	8098	127466H034	3 h.p. motor (ODP)
1	*127466I020	8099	127466I062	5 h.p. motor (ODP)

\* 230 volt only

(QT-5 duplex - horizontal tank - electric motor)

Qty	Part Number	Part Number	Part Number	Description
	<b>80 gal.</b>	<b>120 gal.</b>		
1	113471-200	113467-200		tank (200 PSI maximum operating pressure)
2	N/A	113281		top plate
1	2713	111136-050		tank drain valve
1	111136-075	111136-100		service valve
1	110514-300	110514-300		pressure gauge
1	110512-001	110512-001		pressure switch, 120-150 PSI
1	110512-005	110512-005		pressure switch, 135-175 PSI
1	110513-200	110513-200		pressure relief valve (in tank; 200 PSI)
2	111089-215	111089-215		pressure relief valve (in discharge line; 215 PSI)
2	111491	111491		check valve
8 ft.	110515-075	110515-075		discharge tube
2	110948-075	110948-075		tube fitting (nut with sleeve)
2	2021030889	2021030889		belt guard assembly
	<b>3 h.p.</b>	<b>5 h.p.</b>		
2	110357B057	110258B060		drive belt
2	3844-118	3852-118		motor pulley
	<b>115/230v, 1Ø</b>	<b>200v, 3Ø</b>	<b>230/460v, 3Ø</b>	
2	4003	8098	127466H034	3 h.p. motor (ODP)
2	*127466I020	8099	127466I062	5 h.p. motor (ODP)

\* 230 volt only

Part numbers shown in italics apply to tank mounted units and base mounted units.

# TYPICAL UNIT REPAIR PARTS LIST

The parts listed here are for standard QT-5 (up to 175 PSI) units and may or may not be applicable to custom built units. Check with your local authorized Quincy distributor for parts that can be used for custom built units. Make sure the components you order are rated within the safe operating limits of your system. If you are doubtful about which components to order, contact your local Quincy distributor.

## (QT-5 vertical tank - electric motor)

Qty	Part Number	Part Number	Part Number	Description
	<b>60 gal.</b>	<b>80 gal.</b>		
1	114948P200	114949200		tank (200 PSI max. working pressure)
1	110425-025	110425-050		tank drain valve
1	111136-075	111136-075		ball valve
1	110514-300	110514-300		pressure gauge
1	110512-005	110512-005		pressure switch (135-175 PSI)
1	110513-200	110513-200		pressure relief valve (in tank; 200 PSI)
4 ft.	110515-075	110515-075		! discharge tube (3/4" copper tube to be formed by customer)
2	110948-075	110948-075		tube fitting (nut with sleeve)
1	111491	111491		check valve
1	111089-215	111089-215		relief valve (in discharge line; 215 PSI)
1	2021030889	2021030889		belt guard assembly
	<b>3 h.p.</b>	<b>5 h.p.</b>		
1	110357B057	110258B060		drive belt
1	3844-118	3852-118		motor pulley
	<b>115/230v, 1Ø</b>	<b>200v, 3Ø</b>	<b>230/460v, 3Ø</b>	
1	*4003	8098	127466H034	3 h.p. motor (ODP)
1	*127466I020	8099	127466I062	5 h.p. motor (ODP)

! Pre-formed discharge tubes are available. Contact factory with model & tank size information.

\* 230 volt only.

## (QT-5 gasoline engine driven - Honda)

Qty	Part Number	Part Number	Part Number	Description
	<b>base unit</b>	<b>tank unit</b>		
1		113727P200		30 gallon tank (200 PSI maximum operating pressure)
1	113764			base plate
1		111136-025		tank drain valve
1		111136-050		ball valve
1		110514-300		pressure gauge
1		110513-200		pressure relief valve (in tank; 200 PSI)
1	110357B070	110357B070		drive belt
1	111221	111221		engine pulley
1	110623	110623		engine pulley bushing
1	113702K011	113702K011		belt guard assembly
1	113143-002	113143-002		throttle control (cable bullwhip)
1	115418K004	115418K004		throttle control kit
1	113700-1	113700-1		Honda engine group, 11 h.p. (includes throttle control)
3 ft.		110515-075		! discharge tube (3/4" copper tube to be formed by customer)
2		110948-075		tube fitting (nut with sleeve)
1	111089-215	111089-215		relief valve (in discharge line; 215 PSI)
1	114867-175	114867-175		discharge unloader valve

! Pre-formed discharge tubes are available. Contact factory with model & tank size information.

# TYPICAL UNIT REPAIR PARTS LIST

The parts listed here are for standard QT-5 (up to 175 PSI) units and may or may not be applicable to custom built units. Check with your local authorized Quincy distributor for parts that can be used for custom built units. Make sure the components you order are rated within the safe operating limits of your system. If you are doubtful about which components to order, contact you local Quincy distributor.

(QT-5 diesel engine driven - Yanmar)

Qty	Part Number	Part Number	Part Number	Description
	<b>base unit</b>	<b>tank unit</b>		
1		113727P200		30 gallon tank (200 PSI maximum operating pressure)
1	113764			base plate
1		111136-025		tank drain valve
1		111136-050		ball valve
1		110514-300		pressure gauge
1		110513-200		pressure relief valve (in tank; 200 PSI)
1	110258B070	110258B070		drive belt
1	111221	111221		engine pulley
1	110623	110623		engine pulley bushing
1	113702K006	113702K006		belt guard assembly
1	113143-001	113143-001		throttle control (cable bullwhip)
1	114080-001	114080		Yanmar engine group, 10 h.p. (includes throttle control)
2.5 ft.		110515-075		! discharge tube (3/4" copper tube to be formed by customer)
2		110948-075		tube fitting (nut with sleeve)
1	111089-215	111089-215		pressure relief valve (in discharge line; 215 PSI)
1	110921-177	110921-177		check valve
1	113708-175	113708-175		pilot, 165-175 PSI

! Pre-formed discharge tubes are available. Contact factory with model & tank size information.

# QUINCY COMPRESSOR

## STANDARD TERMS AND CONDITIONS

**LEGAL EFFECT:** Except as expressly otherwise agreed to in writing by an authorized representative of Seller, the following terms and conditions shall apply to and form a part of this order and any additional and/or different terms of Buyer's purchase order or other form of acceptance are rejected in advance and shall not become a part of this order.

The rights of Buyer hereunder shall be neither assignable nor transferable except with the written consent of Seller.

This order may not be canceled or altered except with the written consent of Seller and upon terms which will indemnify Seller against all loss occasioned thereby. All additional costs incurred by Seller due to changes in design or specifications, modification of this order or revision of product must be paid for by Buyer.

In addition to the rights and remedies conferred upon Seller by this order, Seller shall have all rights and remedies conferred at law and in equity and shall not be required to proceed with the performance of this order if Buyer is in default in the performance of such order or of any other contract or order with seller.

**TERMS OF PAYMENT:** Unless otherwise specified in the order acknowledgment, the terms of payment shall be 1% 15, net forty-five (45) days after shipment. These terms shall apply to partial as well as complete shipments. If any proceeding be initiated by or against Buyer under any bankruptcy or insolvency law, or in the judgment of Seller the financial condition of Buyer, at the time the equipment is ready for shipment, does not justify the terms of payment specified, Seller reserves the right to require full payment in cash prior to making shipment. If such payment is not received within fifteen (15) days after notification of readiness for shipment, Seller may cancel the order as to any unshipped item and require payment of its reasonable cancellation charges.

If Buyer delays shipment, payments based on date of shipment shall become due as of the date when ready for shipment. If Buyer delays completion of manufacture, Seller may elect to require payment according to percentage of completion. Equipment held for Buyer shall be at Buyer's risk and storage charges may be applied at the discretion of Seller.

Accounts past due shall bear interest at the highest rate lawful to contract for but if there is no limit set by law, such interest shall be eighteen percent (18%). Buyer shall pay all cost and expenses, including reasonable attorney's fees, incurred in collecting the same, and no claim, except claims within Seller's warranty of material or workmanship, as stated below, will be recognized unless delivered in writing to Seller within thirty (30) days after date of shipment.

**TAXES:** All prices exclude present and future sales, use, occupation, license, excise, and other taxes in respect of manufacture, sales or delivery, all of which shall be paid by Buyer unless included in the purchase price at the proper rate or a proper exemption certificate is furnished.

**ACCEPTANCE:** All offers to purchase, quotations and contracts of sales are subject to final acceptance by an authorized representative at Seller's plant.

**DELIVERY:** Except as otherwise specified in this quotation, delivery will be F. O. B. point of shipment. In the absence of exact shipping instruction, Seller will use its discretion regarding best means of insured shipment. No liability will be accepted by Seller for so doing. All transportation charges are at Buyer's expense. Time of delivery is an estimate only and is based upon the receipt of all information and necessary approvals. The shipping schedule shall not be construed to limit seller in making commitments for materials or in fabricating articles under this order in accordance with Seller's normal and reasonable production schedules.

Seller shall in no event be liable for delays caused by fires, acts of God, strikes, labor difficulties, acts of governmental or military authorities, delays in transportation or procuring materials, or causes of any kind beyond Seller's control. No provision for liquidated damages for any cause shall apply under this order. Buyer shall accept delivery within thirty (30) days after receipt of notification of readiness for shipment. Claims for shortages will be deemed to have been waived if not made in writing with ten (10) days after the receipt of the material in respect of which any such shortage is claimed. Seller is not responsible for loss or damage in transit after having received "In Good Order" receipt from the carrier. All claims for loss or damage in transit should be made to the carrier.

**TITLE & LIEN RIGHTS:** The equipment shall remain personal property, regardless of how affixed to any realty or structure. Until the price (including any notes given therefore) of the equipment has been fully paid in cash, Seller shall, in the event of Buyer's default, have the right to repossess such equipment.

**PATENT INFRINGEMENT:** If properly notified and given an opportunity to do so with friendly assistance, Seller will defend Buyer and the ultimate user of the equipment from any actual or alleged infringement of any published United States patent by the equipment or any part thereof furnished pursuant hereto (other than parts of special design, construction, or manufacture specified by and originating with Buyer), and will pay all damages and costs awarded by competent court in any suit thus defended or of which it may have had notice and opportunity to defend as aforesaid.

**STANDARD WARRANTY:** Seller warrants that products of its own manufacture will be free from defects in workmanship and materials under normal use and service for the period specified in the product instruction manual. Warranty for service parts will be Ninety (90) days from date of factory shipment. Electric Motors, gasoline and diesel engines, electrical apparatus and all other accessories, components and parts not manufactured by Seller are warranted only to the extent of the original manufacturer's warranty.

Notice of the alleged defect must be given to the Seller, in writing with all identifying details including serial number, type of equipment and date of purchase within thirty (30) days of the discovery of the same during the warranty period.

Seller's sole obligation on this warranty shall be, at its option, to repair or replace or refund the purchase price of any product or part thereof which proves to be defective. If requested by Seller, such product or part thereof must be promptly returned to seller, freight prepaid, for inspection.

Seller warrants repaired or replaced parts of its own manufacture against defects in materials and workmanship under normal use and service for ninety (90) days or for the remainder of the warranty on the product being repaired.

This warranty shall not apply and Seller shall not be responsible or liable for:

- (a) Consequential, collateral or special losses or damages;
- (b) Equipment conditions caused by fair wear and tear, abnormal conditions of use, accident, neglect or misuse of equipment, improper storage or damage resulting during shipping;
- (c) Deviation from operating instructions, specifications or other special terms of sale;
- (d) Labor charges, loss or damage resulting from improper operation, maintenance or repairs made by person(s) other than Seller or Seller's authorized service station.

In no event shall Seller be liable for any claims whether arising from breach of contract or warranty or claims of negligence or negligent manufacture in excess of the purchase price.

**THIS WARRANTY IS THE SOLE WARRANTY OF SELLERS AND ANY OTHER WARRANTIES, WHETHER EXPRESS OR IMPLIED IN LAW OR IMPLIED IN FACT, INCLUDING ANY WARRANTIES OF MERCHANTABILITY AND FITNESS FOR PARTICULAR USE ARE HEREBY SPECIFICALLY EXCLUDED.**

**LIABILITY LIMITATIONS:** Under no circumstances shall the Seller have any liability for liquidated damages or for collateral, consequential or special damages or for loss of profits, or for actual losses or for loss of production or progress of construction, whether resulting from delays in delivery or performance, breach of warranty, negligent manufacture or otherwise.

**ENVIRONMENTAL AND OSHA REQUIREMENTS:** At the time of shipment of the equipment from the factory, Quincy Compressor / Ortman Fluid Power will comply with the various Federal, State and local laws and regulations concerning occupational health and safety and pollution. However, in the installation and operation of the equipment and other matters over which the seller has no control, the Seller assumes no responsibility for compliance with those laws and regulations, whether by the way of indemnity, warranty or otherwise.

June 30, 2003







Reciprocating / Systems: 217.222.7700  
E-mail: [info@quincycompressor.com](mailto:info@quincycompressor.com)  
Website: [quincycompressor.com](http://quincycompressor.com)

